

ZINSER 1304

Universal Pipe Cutting Machine with 2 axes for oxy-fuel or plasma cutting plus drilling of cylindrical pipes



Technical Data:	ZINSER 1304	ZINSER 1306
Pipe diameter (standard)	50-500 mm	
Cutting length (Working length)	Basic length: 1.000 mm Extensions in steps of 1.000 mm	
Working width at Y-cantilever	–	~ 500 mm (with one tool)
Equipment:	1 torch with height adjustment; Oxy-fuel / Plasma / Drilling	
Option	Pipe support system consisting of a guide track and height adjustable dollies	



CUTTING
WELDING

SINCE 1898



Subject to changes and possible errors 11.12 504 1101-00211 ZINSER 1304/06



Welding Company NV Belgium | Welding Company NV Nederland BV
 Brandekensweg 6 - 2627 Schelle | Ambachtsweg 2 - 4128LC Lexmond
 +32 (0)3 880 81 80 | +31 (0)347 745 008
 info@weldingcompany.be | info@weldingcompany.nl



CUTTING
WELDING

SINCE 1898



ZINSER 1304 / ZINSER 1306

Universal Pipe Cutting Machines for oxy-fuel or plasma cutting plus drilling for cylindrical and multi-sided pipes



**Made in
Germany**
Since 1898



ZINSER 1304 / ZINSER 1306

Universal Pipe Cutting Machines for oxy-fuel or plasma cutting plus drilling for cylindrical and multi-sided pipes

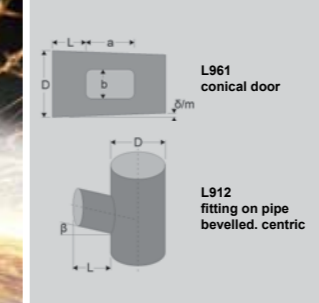
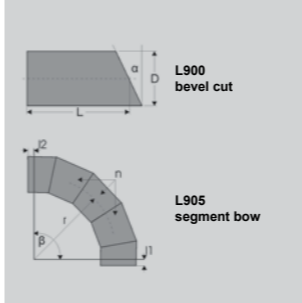

The ZINSER cutting machines 1304 and 1306 have been particularly developed for efficient machining of pipes (ZINSER 1304 for cylindrical pipes, ZINSER 1306 for cylindrical and multi-sided pipes). Apertures, notches and the entire end preparation can be realized quickly and economically. A variety of standard figures

is available from the ZINSER MCC software. With the new generation of ZINSER machines you will get excellent results at reduced piece costs. We will build the ideal machine to cope with your requirements by choosing the right components and upgrades from the wide ZINSER product range.

Basic scope of delivery

- Pipe cutting machine with track (X), rotation axis (A) and for the ZINSER 1306 with additional cantilever (Y)
- Three-jaw chuck or four-jaw chuck
- CNC-controller
- Oxy-fuel cutting unit or plasma power source with dialogue system

Options / accessory equipment

- Pneumatic jaw chuck
- Drilling unit
- Extraction systems and filter units

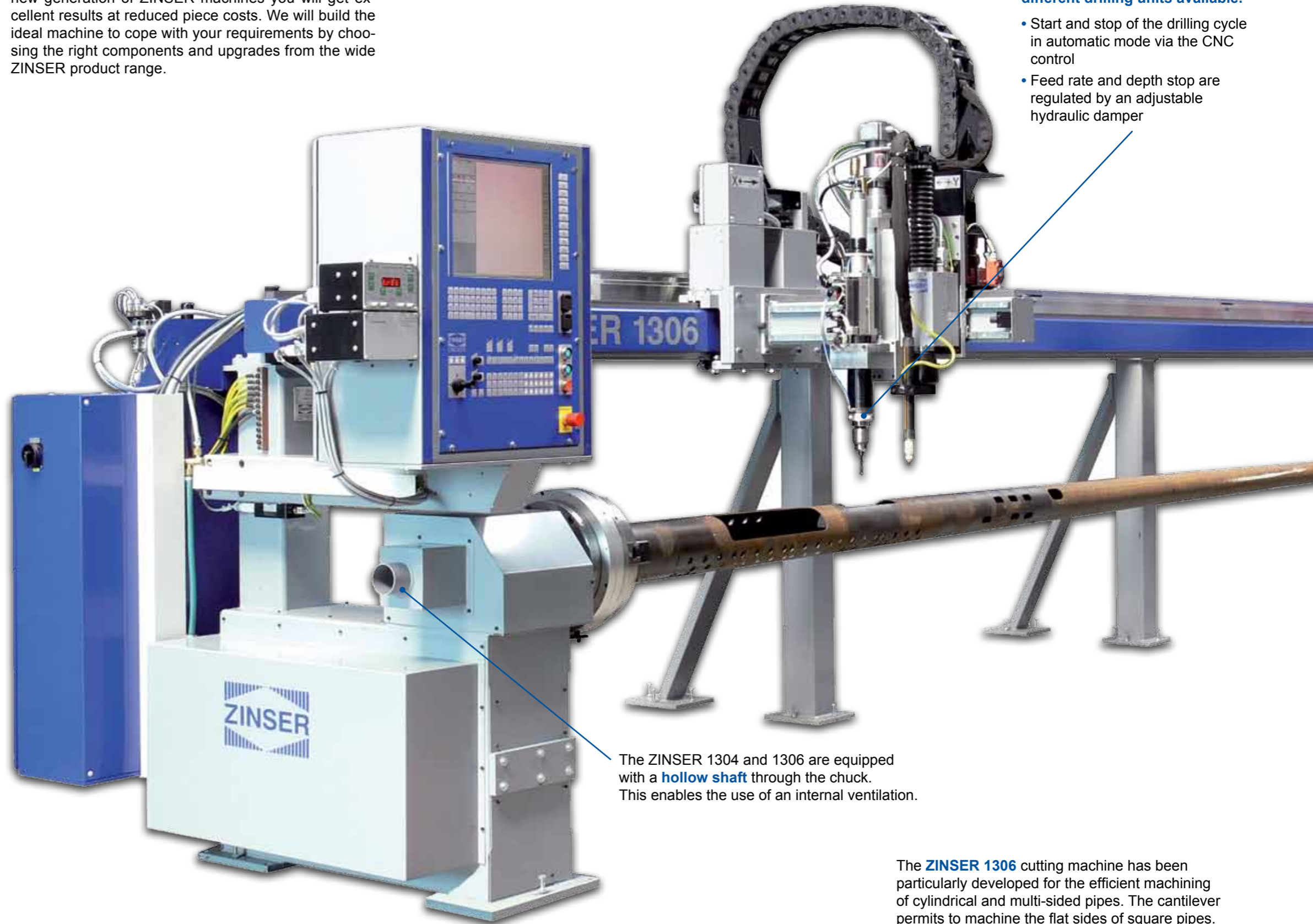
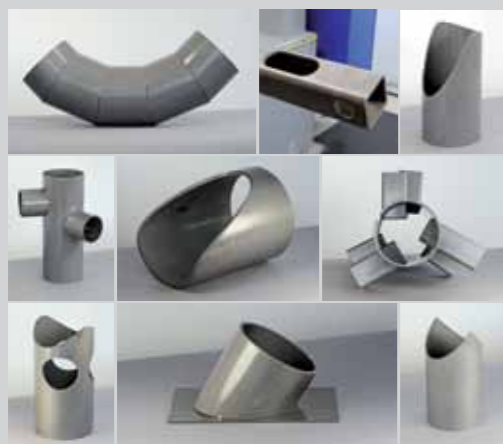

As option there is a range of different drilling units available.

- Start and stop of the drilling cycle in automatic mode via the CNC control
- Feed rate and depth stop are regulated by an adjustable hydraulic damper

The ZINSER 1304 and 1306 are equipped with a **hollow shaft** through the chuck. This enables the use of an internal ventilation.

The **ZINSER 1306** cutting machine has been particularly developed for the efficient machining of cylindrical and multi-sided pipes. The cantilever permits to machine the flat sides of square pipes.

CUTTING
WELDING

SINCE 1898

